

Magnetically operated switch Ex m

Bistable change-over switch with patented switch element
Switch contacts magnetically operated
Pipe clamp integrated

Product group **740**

Type **0062**

Sheet: 1/1

Revision: 4

Date:

08/04

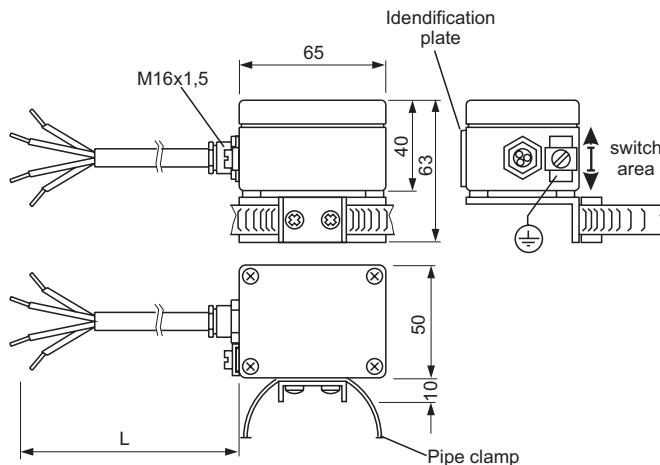

measures in mm

Connection diagram

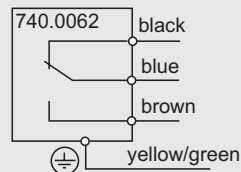

Range of application

This SPDT switch is for signalling level limits of magnetically operated liquid level gauges. It works with contact types which need not be protected by special means and so may be operated with higher loads. The switch can be used for Ex-Zone 2 and Ex Zone 1.

General Data

Hysteresis: 18 mm (with Type 710.100)
Material housing: Aluminium
Fixing device for magnetic gauge type:
A: 710.100.0/104/2XX.0 pipe clamp Ø40-60 mm
B: 710.102/103/106...140 pipe clamp Ø60-80 mm

Design Data

Temperature ambient: -45 to +125 °C
Temperature housing: -65 to +125 °C
Temperature in gauge pipe: up to 400 °C *)
Switch cycles: > 10⁵
*) Insulate between switch and gauge pipe above 150 °C in pipe
Ex-protection: EEx m II T4, T5, T6
Ambient temperature for temperature class:
T4: -45 °C to +125 °C
T5: -45 °C to +95 °C
T6: -45 °C to +80 °C

Function

MAX (Float above): black - blue closed
MIN (Float below): brown - blue closed

Electrical Data

Switch over bistable: SPDT
Switch voltage: 200 V =/250 V~
Switch current: 2 A~/~
max. power limit: 40 W/100 VA
Contact material: AgCd / Au5µ
Transit time: < 50 ms
Connection: 3 m silicone cable (resistantly approximately nick) 4 x 0,75 mm²
Ingress protection acc. to EN 60529: IP 67

Certificates

EC-Type-Examination Certificate: ZELM 02 ATEX 0079

Subject to alterations

Ordering no.

740.0062 - X - XXX - cable length L in m

A	710.100.0/104/2XX.0	for magnetic gauge type
B	710.102/103/106...140	

PHÖNIX

Messtechnik GmbH
Salzschlirfer Straße 13
D-60386 Frankfurt/M.
Tel. +49/69/41 67 42 -20
Fax +49/69/41 67 42 -29
sales@phoenix-mt.com
www.phoenix-mt.com

PHÖNIX